

# ESDA Series Driver User's Manual

## *Contents*

<b>1. Introduction .....</b>	<b>2</b>
<b>1.1. Unpacking .....</b>	<b>2</b>
<b>1.2. Relocation .....</b>	<b>2</b>
<b>1.3. Safety Precautions .....</b>	<b>3</b>
<b>1.4. Installation.....</b>	<b>3</b>
<b>1.5. Dimensions .....</b>	<b>5</b>
<b>2. System Wiring .....</b>	<b>9</b>
<b>2.1. Unit Overview .....</b>	<b>9</b>
<b>2.2. CN1 Connector .....</b>	<b>10</b>
2.2.1. Input Ports Connection .....	11
2.2.2. Output Ports Connection .....	13
2.2.3. Command Pulse Input Ports Connection.....	14
2.2.4. Encoder Signal Output .....	16
<b>2.3. CN2 encoder connector .....</b>	<b>18</b>
<b>2.4. Connection Diagram .....</b>	<b>19</b>
<b>2.5. Power and motor connection diagram.....</b>	<b>20</b>
<b>2.6. RS232 .....</b>	<b>20</b>
2.6.1. PC Communication port setting .....	21
2.6.2. Read data from driver .....	21
2.6.3. Write data to driver .....	22
2.6.4. Memory map .....	24
<b>3. Panel operation.....</b>	<b>25</b>
<b>3.1. Mode selection : .....</b>	<b>26</b>
<b>3.2. Auxiliary functions .....</b>	<b>26</b>
3.2.1. Historical alarm code.....	27
3.2.2. Clear the historical alarm codes.....	27
3.2.3. Jog.....	28
3.2.4. Firmware version.....	28
3.2.5. Reset – Warm start.....	29
3.2.6. Input ports status.....	29
3.2.7. Output ports status .....	30
3.2.8. Reload the default values.....	31

3.2.9. Lock & Unlock .....	31
<b>3.3. User Parameters .....</b>	<b>32</b>
<b>3.4. Monitor mode.....</b>	<b>38</b>
<b>4. Alarm code.....</b>	<b>40</b>

# 1. Introduction

Thank you for choosing ESDA series AC servo Drivers. ESDA series Drivers use the digital servo technology to provide high-precision and versatile functions for driving servo motors. Many safety related features have been built in the Driver design. However, erroneous operation may result in unpredictable accident and cause damage to the Driver or severe personal injury. It is highly recommended that the user is familiar with this manual and performs all setup and operations with caution.

This manual provides the information you need to install and configure ESDA series Driver. This manual is intended for use by vendors who are responsible for installing and setting up ESDA series Driver; consequently, it assumes a basic working knowledge of AC servo Motors.

In this manual, the installation related information such as **Dimensions and Specifications** are described in Chapter 1. **Wiring information** is shown in Chapter 2. Procedures for **Panel Operation** are described in Chapter 3. Finally, the **Alarm Codes** are given in Chapter 4.

## 1.1. Unpacking

After receiving the shipment from your supplier, please verify the following:

1. The motor (s) and driver(s) are the same as ordered.
2. The capacity of the driver matches with the motor to be driven.  
(Please see the Driver Specification for correct driver.)
3. No damage to the packaging material occurred during transportation.

## 1.2. Relocation

Please use the original packaging for driver relocation and handle with care.

## 1.3. Safety Precautions

1. Many high volume capacitors are used in the Driver circuit; these capacitors remain charged even if the unit power is been shut off. If it is necessary to touch the terminal or open the driver chassis, **please wait at least 10 minutes** before continuing.
2. While power on the Driver and/or motor, stand clear from the unit to prevent personal injury caused from erroneous operation.
3. Disconnect the power if the Driver/Motor unit is not used for a prolonged period.
4. To prevent electric leakage, connect the motor ground to the FG terminal of the Driver and connect this FG to Class 3 grounding. The machine, which the Driver and motor are installed must be single-point grounded.

## 1.4. Installation

### 1. Location

- (1) If installed in a confined chassis, please provide necessary ventilation system to maintain the environmental temperature of the Driver below 55 °C.
- (2) Use rubber pad or shock absorber to insulate vibration if there is vibrating equipment nearby.
- (3) The Driver shall not be installed in an environment where corrosive gases, excess dust, or metal powder is present. Insulation from water, water mist, or cutting fluid is required.
- (4) If there is a big magnet switch or welding equipment, which may generate electronic noise, near the Driver installation, then a line filter is required.  
Recommend filter:  
For single-phase power source: DELTA 06DPCW5
- (5) If a line filter is not allowed for the reason of excess leakage current, then a insulating transformer is required at the input of the Driver.

### 2. Orientation

The Driver must be installed vertically.

### 3. Mounting Screw

Use **four (4) M5 screws** to mount the Driver securely.

#### **4. Spacing**

Maintain **at least 2 cm** spacing around the Driver unit.

#### **5. Foreign objects**

During and after installation, any foreign object such as cutting chips, small screw, or washer which may fall into the opening of the Driver unit must be prevented.

# 1.5. Dimensions

Model ESDA15:

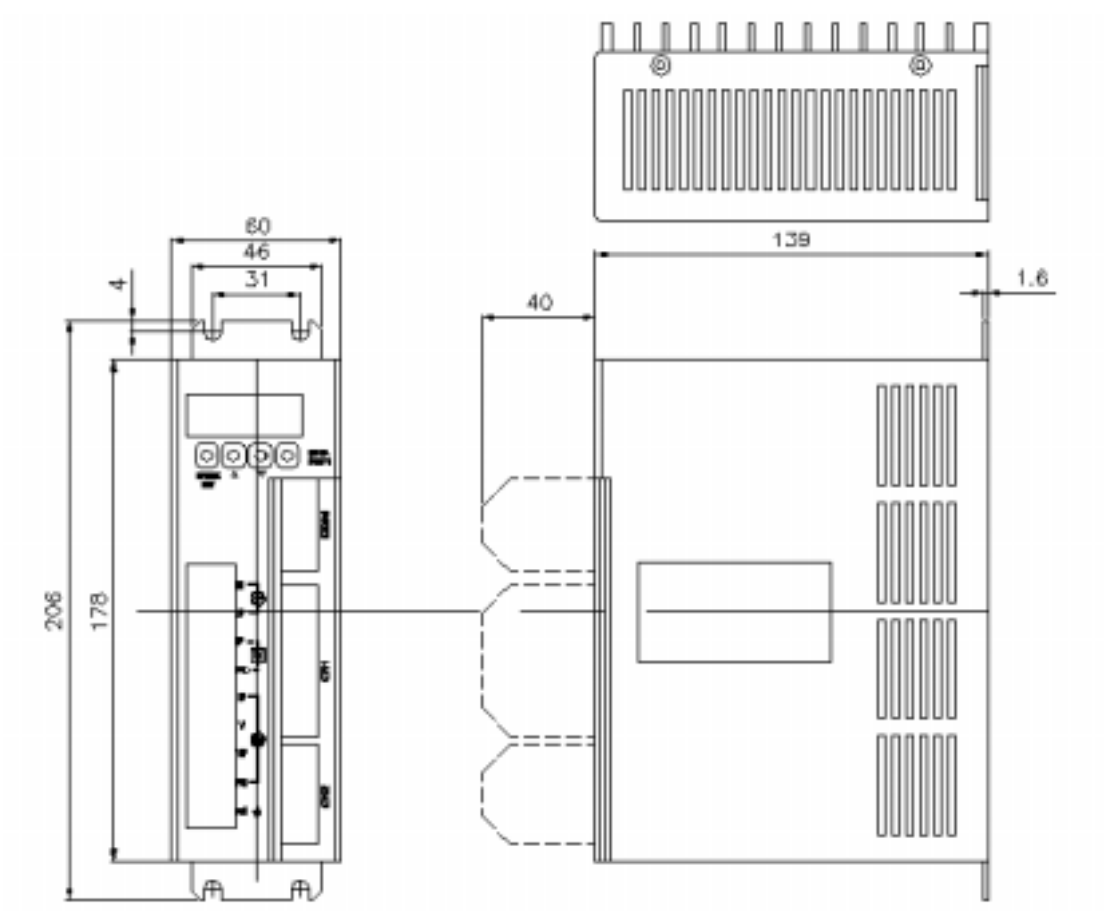

**Model ESDA20:**

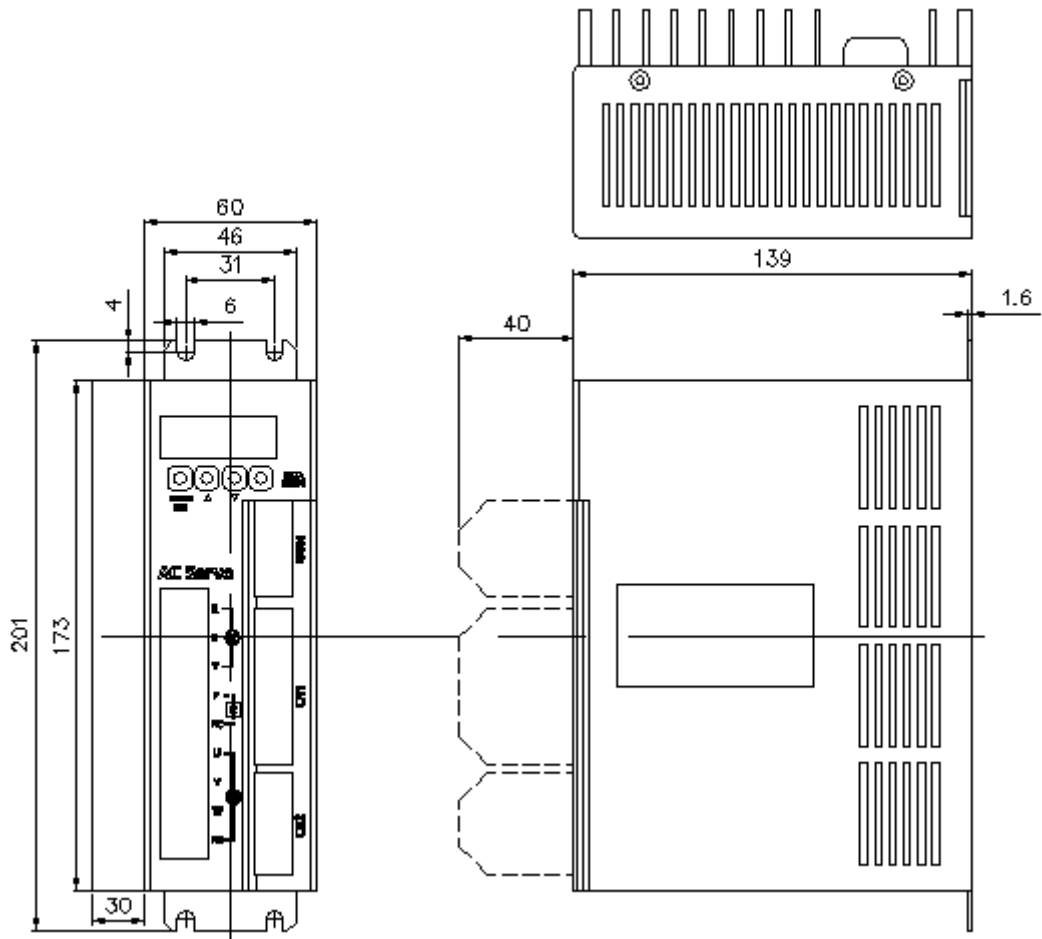

**Model ESDA30,40:**

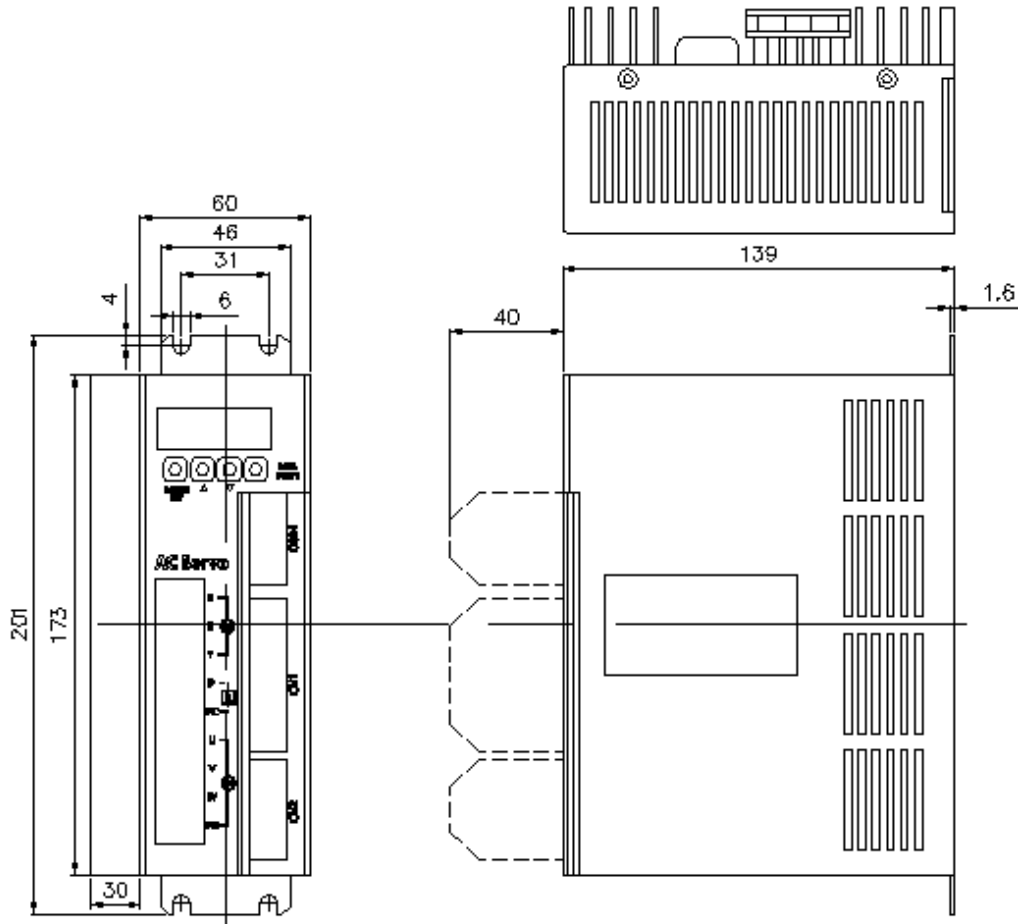

## Specifications

### General Specifications:

Driver		Description			
Model No.	ESDA15	ESDA20	ESDA30	ESDA40	
Maximum Peak Current (A)	8.4A	11.4A	17.0A	22.8A	
Maximum Rated Current(A)	2.8A	3.8A	5.7A	7.6A	
Model No.	AC180V~240V Single-Phase 50 / 60 Hz		AC180V~240V Three-Phase 50 / 60 Hz		
Encoder	Incremental type				
Environment	Temperature	Operation: 0 ~ 50°C Storage: -20 ~ 80°C			
	Humidity	Operation/Storage: < 85% RH			
	Vibration	< 0.5G			
Manual Operation	May be defined by User's Parameter				
Error Message	10 error messages are stored.				
Over-Travel inhibit	Positive or Negative Over-Travel inhibit (If over-travel is occurred, the servo power may be disabled or put on hold.)				
Encoder Output	A, B, Z Phase line driver output				
Display	5-digit LED display, 4 button				
D/I	Servo ON, Pulse Input Inhibit, Clear Error Counter.				
D/O	Alarm, In Position				
Communication	RS-232C for User's Parameter setting and status monitoring				
Input type	A-B phase, Up-Down pulse, or direction pulse				
Max. Input Freq.	500kpps				
Electronic Gear Ratio	$1/127 \leq A/B \leq 127$ (A&B:1 ~ 10000)				
Input Ripple Filtering	Time Constant = 0 ~ 10000ms				
In position range	0 ~ 32767 Pulses				

# 2. System Wiring

## 2.1. Unit Overview

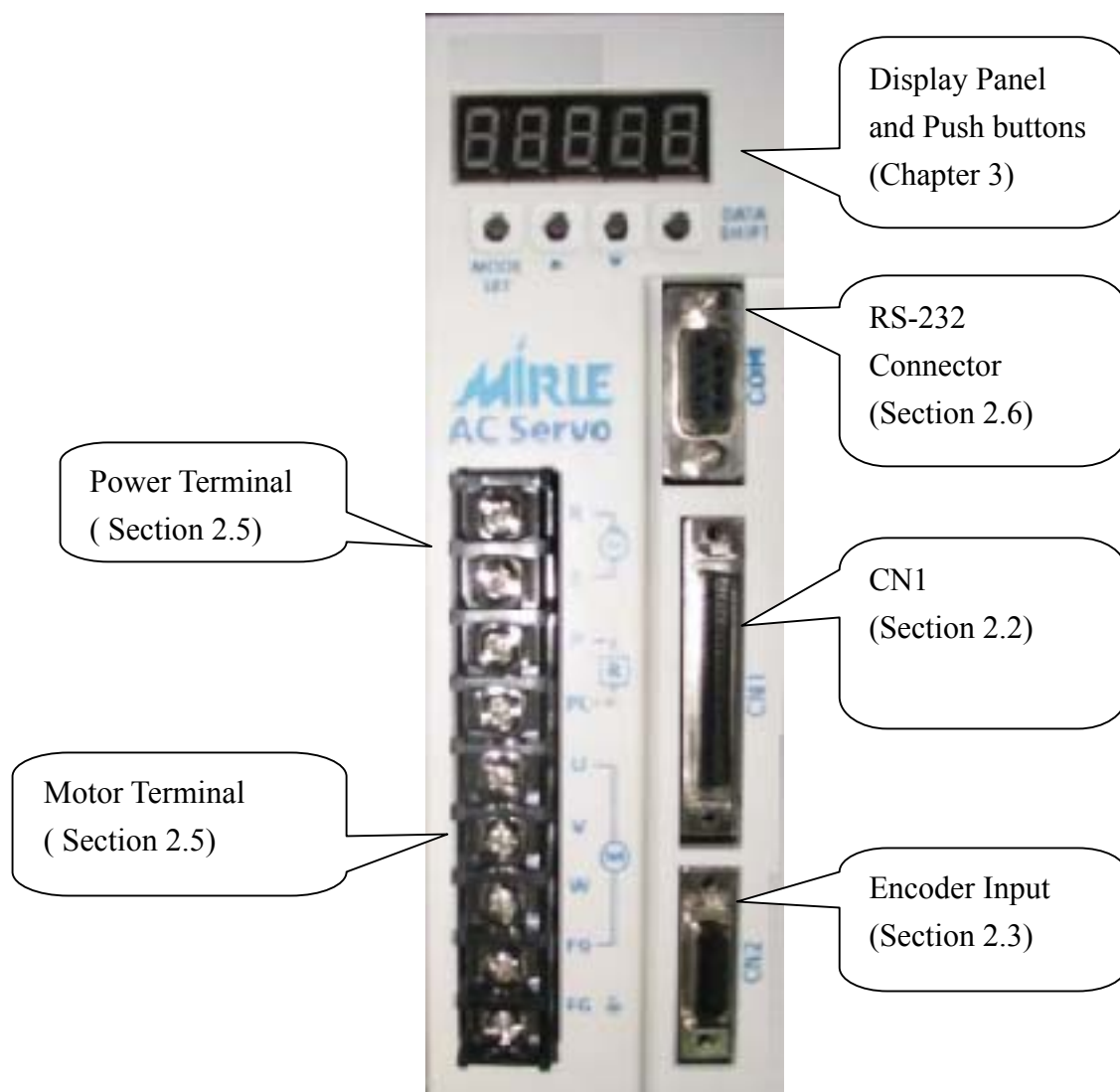

## 2.2. CN1 Connector



Pin no	Name	Sym bol	Function			
1	Servo on	SON	SON connects to DG means servo on or servo system ready, open circuit means servo off.			
2	Clear error counter	CLR	Clear error counter			
3	Command pulse inhibit	INH	Ignore the input command pulses.			
	Internal speed inverse		Set internal speed to be inversed			
4	Pulse +	PP	5V Input pulse.  (The type is set by PN10-2)	PN10-2 value	Pin 4,5	Pin 6,7
5	Pulse -	PN		0,4	Positive	Negative
6	Direction +	DP		1,5	Pulse	Direction
7	Direction -	DN		2,6	Phase A	Phase B
8	Pulse +	PPR	24V pulse input pin			
9	Direction +	DPR	24V direction input pin			
10	Input power	P	Common point of Input ports, 0V for PNP type connection, 12V / 24V for NPN type.			
11			Reserved			
12			Reserved			
13			Reserved			

Pin no	Name	Sym bol	Function
14	Alarm	ALM	ALM connects to DG normally; it is open when any abnormal condition is detected.
15	In position	INP	When the pulses difference between the command pulses and the feedback pulses is less than the value set in the PN20. The INP signal turns ON (INP connects to DG).
16	Encoder phase A output	PA	Encoder input pulses after frequency division (PN0) is output by line driver. When PN10-3 is 1, the motor rotation direction is CCW, phase A lead by 90 degree.
17		/PA	
18	Encoder phase B output	PB	
19		/PB	
20	Encoder phase Z output	PZ	Transfer the Z phase of the encoder input signal.
21		/PZ	
22	Output port ground	N	Ground for output ports.
23			Reserved
24			Reserved
25	Shielding	FG	Connect to the shielding of the cable

## 2.2.1. Input Ports Connection

Input port internal circuits

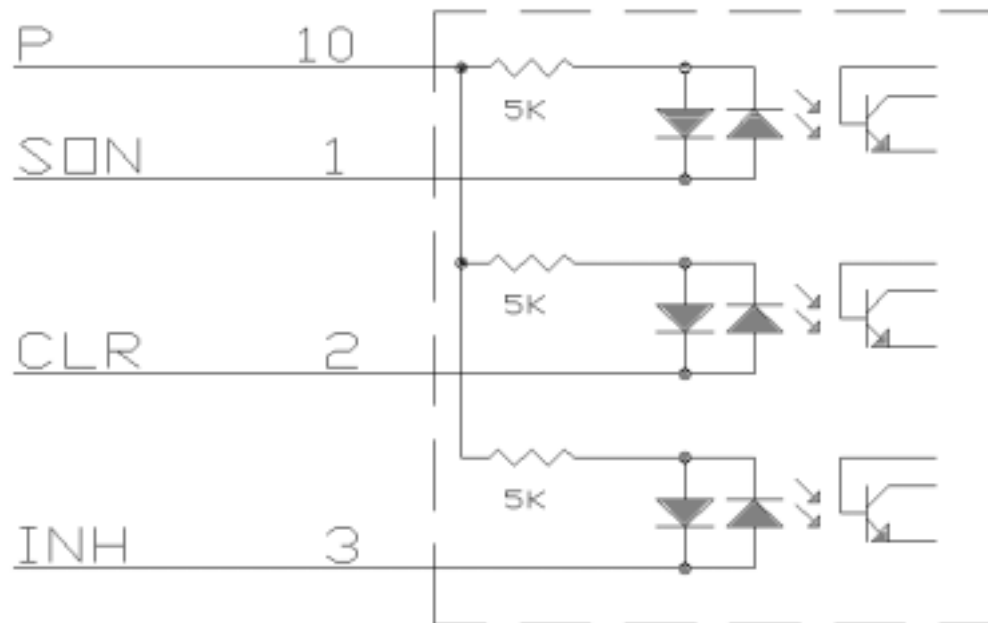

Connect with NPN type output:

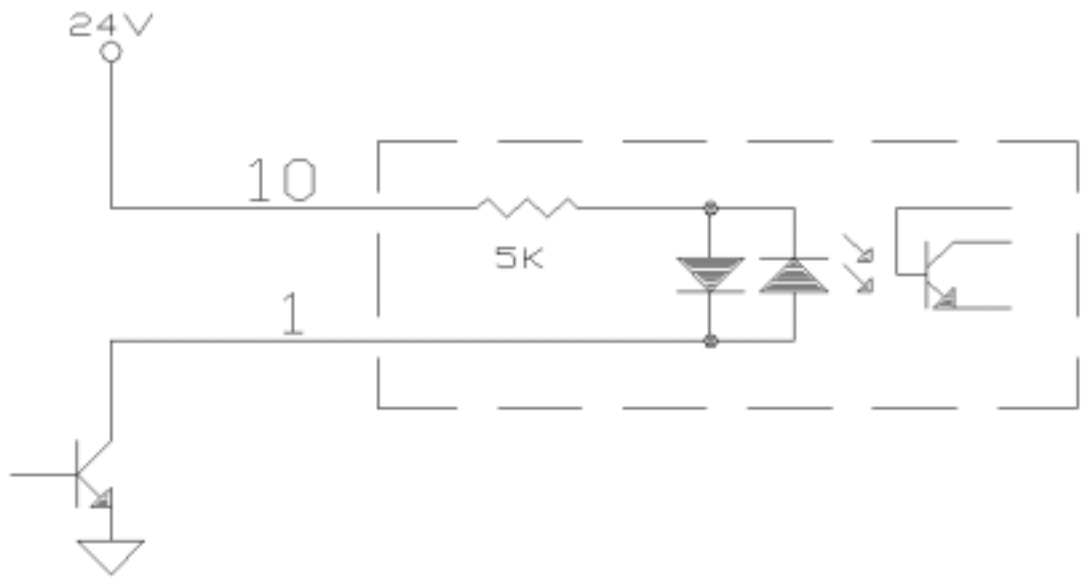

Connect with PNP type output

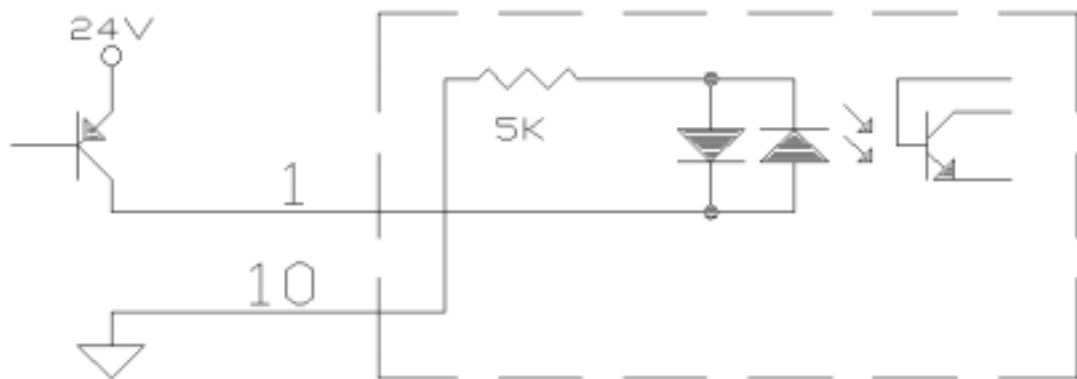

## 2.2.2. Output Ports Connection

Output port internal circuits

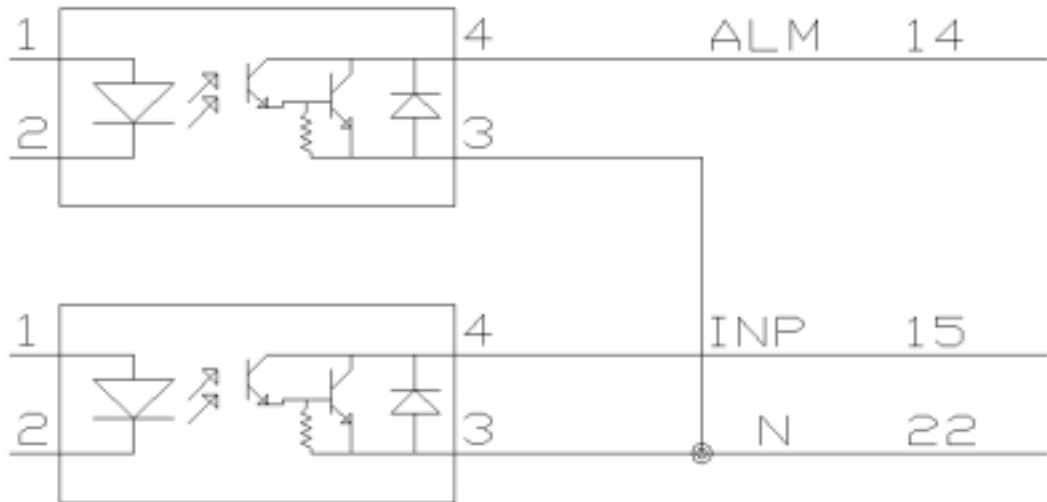

The maximum current allowable for each port is 50mA.

Standard wiring for connect with photo coupler:

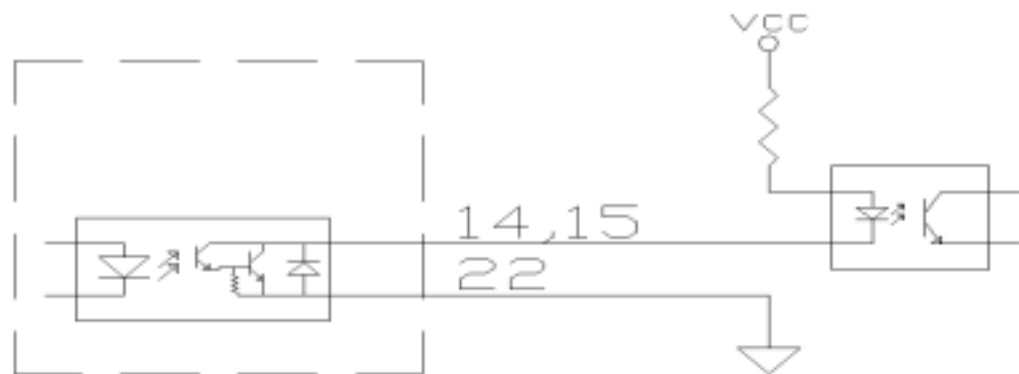

Standard wire for connect with Relay coil:

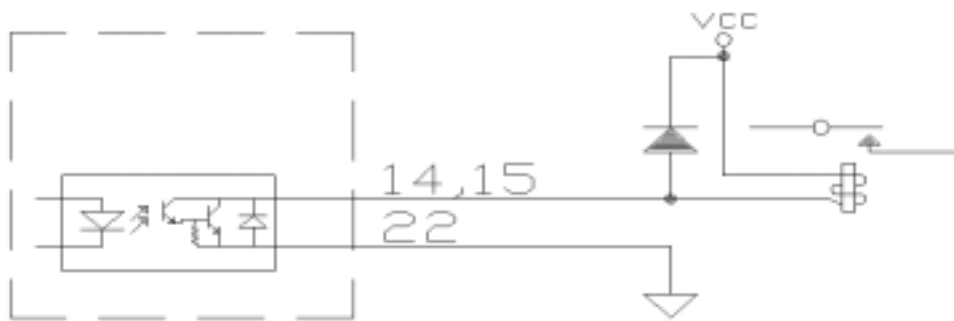

### 2.2.3. Command Pulse Input Ports Connection

Internal circuits for command pulse input ports:

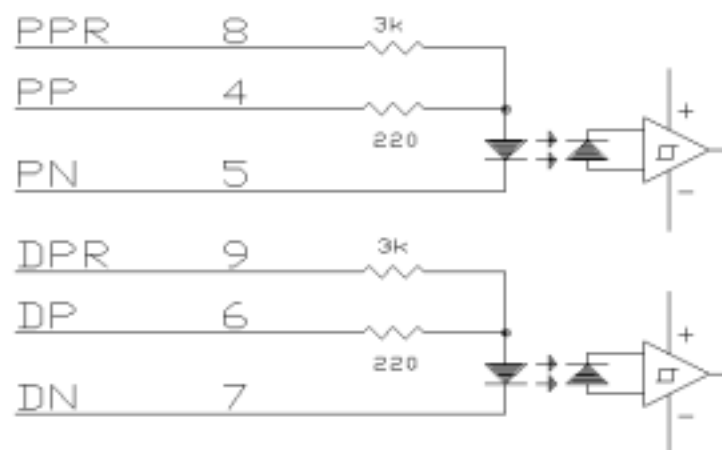

Wiring Diagram for Connecting with Differential Devices (e.g. AM26LS32, SN75174 ).

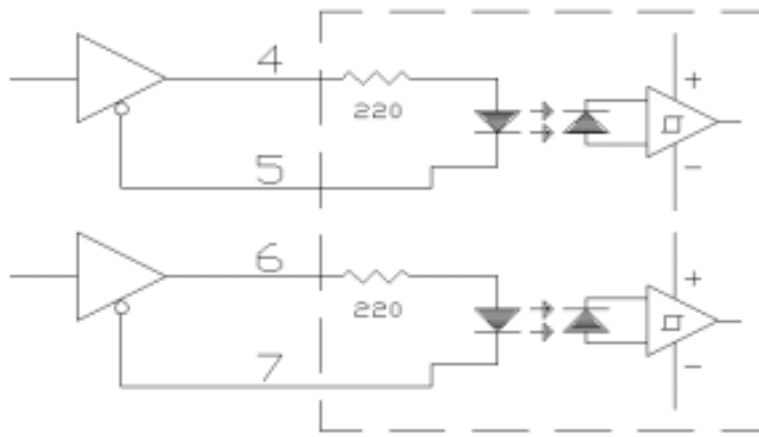

Connection Diagram for connecting with 24V open collector devices:

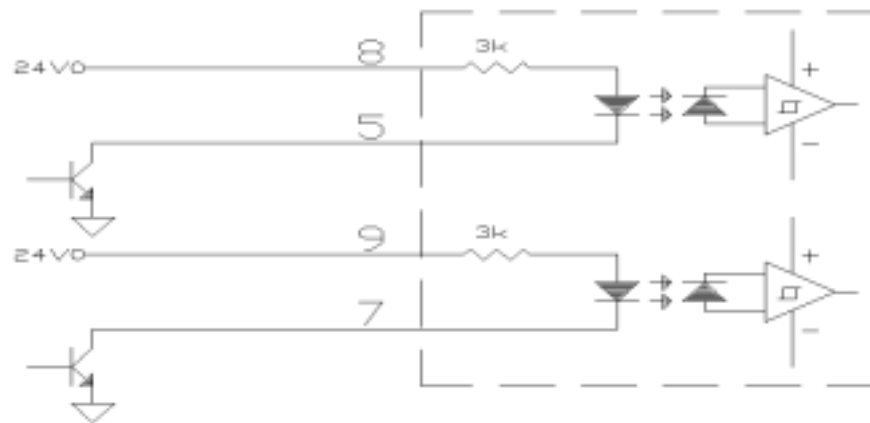

Connection Diagram for connecting with 12V open collector devices:

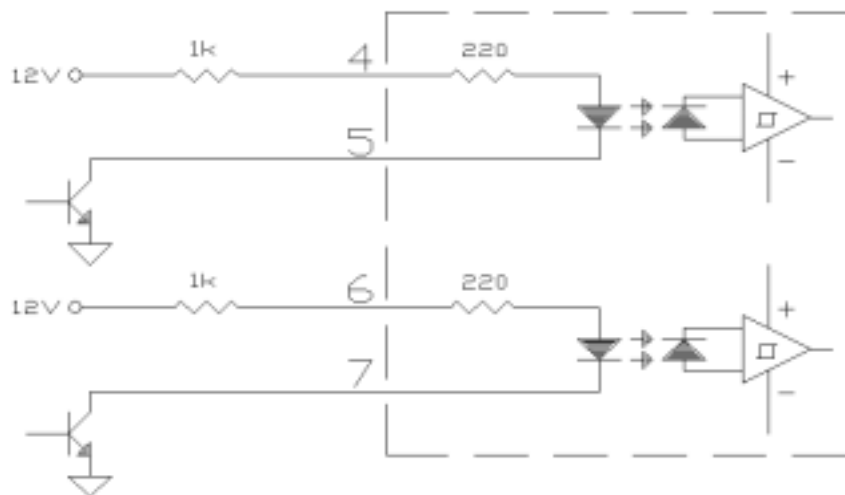

Replace the 1k resistor with 100Ω resistor if 5V power is used.

## 2.2.4. Encoder Signal Output

Encoder signal outputs transfer encoder pulses from the encoder mounted with motor.

Connection diagram for connecting with upper controller:

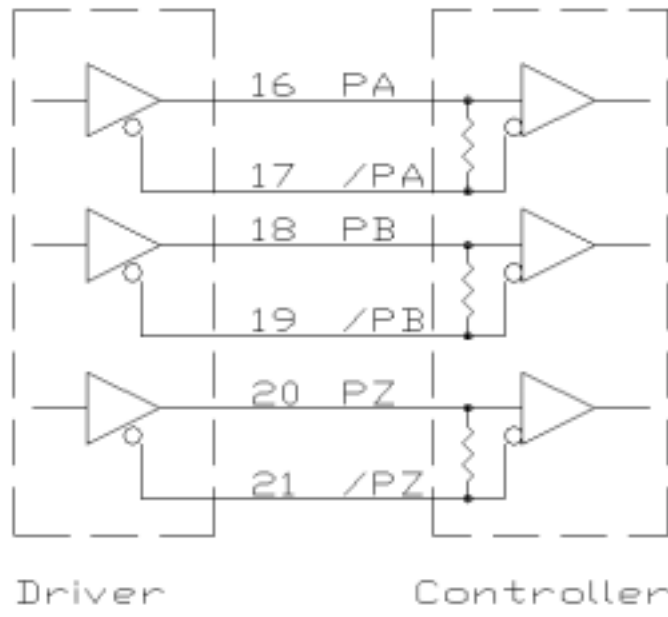

## 2.3. CN2 encoder connector

Pin no	Name	Symbol	Function
1	5V	+5V	If the wire length for the encoder is longer than 20m, please use double wire to minimize voltage drop. If the wire is longer than 30m, please consult with your supplier for recommended wire gage.
2	0V	0V	
3	A	A	Encoder phase A
4	/A	/A	Encoder phase /A
5	B	B	Encoder phase B
6	/B	/B	Encoder phase /B
7	Z	Z	Encoder phase Z
8	/Z	/Z	Encoder phase /Z
9	Shielding	FG	Connect to the shielding of cable.

## 2.4. Connection Diagram

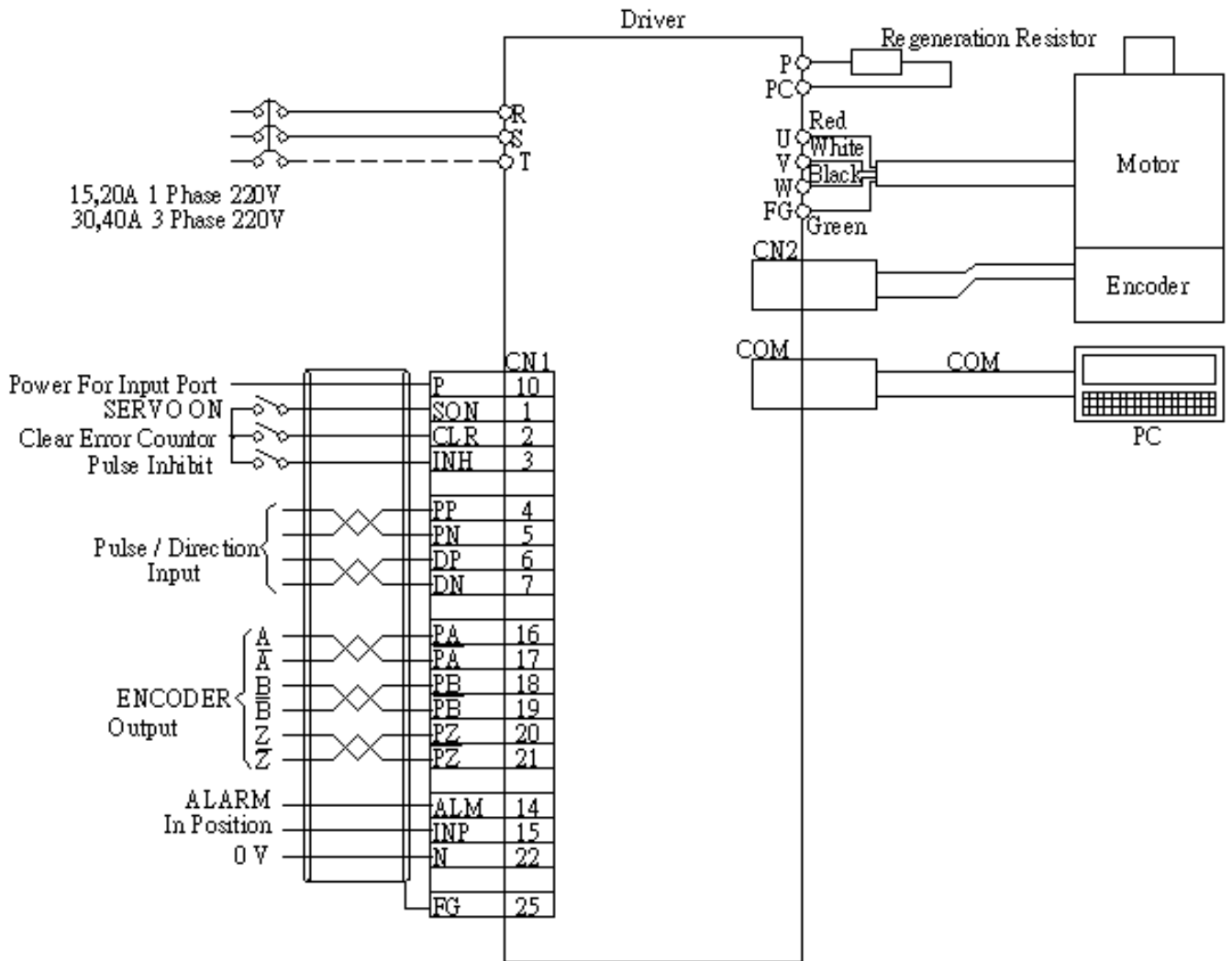

15/20 Amp model : Leave terminal T unconnected

## 2.5. Power and motor connection diagram

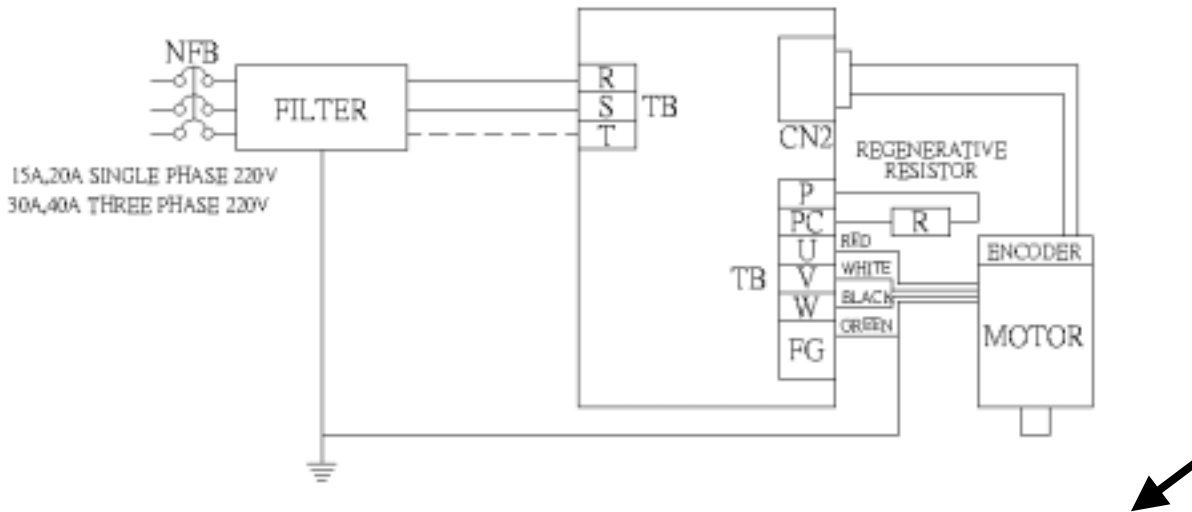

**15 and 20 Amp model : leave terminal T unconnected**

### Recommended line filter:

15A, 20A: DELTA 06DPCW5

30A: DELTA 08TDS4W4

### Regenerative Resister:

When the inertia presented on the motor is heavy, a regenerative resistor is required. The value of the resistor may be obtained by dividing the wattage of the Resistor from 2500. For example, a 50Ω 50W Resistor is recommended for a 20 or 30Amp driver. If “error02” (Chapter4) persists, then adjusting the regeneration duty cycle (Pn040, Section 3.3) is also required. Select suitable wattage for the resistor, forced cooling (by fan) may be required for proper heat dissipation.

## 2.6. RS232

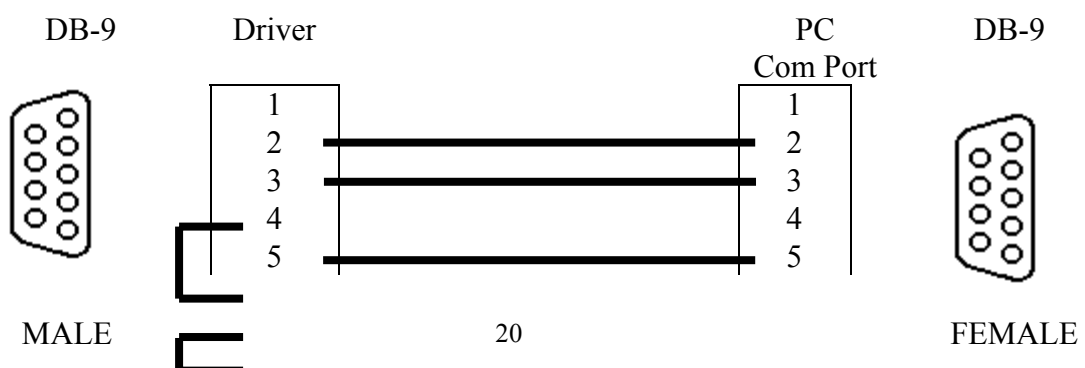



Please use the cable described above to connect the servo-driver to a PC for retrieving the system data and setting up the operation parameter.

## 2.6.1. PC Communication port setting

Baud rate: **9600** bps

Parity: **None**

Data bit: **8**

Stop bit: **1**

Flow Control: **None**

## 2.6.2. Read data from driver

◎ To read a **SINGLE-WORD** from driver

Syntax : **R5XxSs** The read command must be started with “R5” and the command string length must be “6”.

Where: R5: This is a single-word read command.

Xx = the address of the data to be read.

Ss = Check Sum = 'R'+ '5'+ 'X'+ 'x'

Example :

Read the data stored in 30H.

Check Sum = 52H + 35H + 33H + 30H = EAH

R 5 3 0

Thus, the reading command is “R530EA” : R(52H) 、 5(35H) 、 3(33H) 、 0(30H) 、 E(45H) 、 A(41H).

◎ Drive’s response: **%XxYySs**

Where: %: This is a response.

Xx = High word of data

Yy = Low word of data

Ss = Check Sum = '%'+ 'X'+ 'x'+ 'Y'+ 'y'

If the data stored in the address 30H is 0008H, then

Check Sum = 25H + 30H + 30H + 30H + 38H = EDH

% 0 0 0 8

Thus, the receiver's response is “%0008ED” : %(25H) 、 0(30H) 、 0(30H) 、 0(30H) 、 8(38H) 、 E(45H) 、 D(44H).

If there is a Check Sum error in the read command, then the driver returns “!( 21H)”

◎To read a **DOUBLE-WORD** from driver

Syntax : **L5NnSs** The read command must be started with “L5” and the command string length must be “6”.

Where: L5: This is a double word read command.

Nn = the address of the data to be read.

Ss = Check Sum = 'L'+ '5'+ 'N'+ 'n'

◎Driver's response: **%XxYyAaBbSs**

Where: %: This is a response.

XxYy = data stored in Nn+1

AaBb = data stored in Nn

Ss='%'+'X'+ 'x'+ 'Y'+ 'y'+ 'A'+ 'a'+ 'B'+ 'b'

If there is a Check Sum error in the read command, then the driver returns “!( 21H)”

### 2.6.3. Write data to driver

◎To write a **SINGLE-WORD** to driver

Syntax : **W5XxYyZzSs** The write command must be started with “W5” and the command string length must be “8”.

Where: W5: This is a single-word write command.

Xx = the address of the data to be written.

Yy = the high word of the data

Zz = the low word of the data

Ss = 'W'+ '5'+ 'X'+ 'x'+ 'Y'+ 'y'+ 'Z'+ 'z'

Example: Write “8” to address “30H”.

Check Sum=57H+35H+33H+30H+30H+30H+30H+38H=1B7H

W 5 3 0 0 0 0 8

Thus, the write command is W5300008B7: W(57H) 、 5(35H) 、 3(33H) 、 0(30H) 、 0(30H) 、 0(30H) 、 0(30H) 、 8(38H) 、 B(42H) 、 7(37H)

Please note that only the last two digits of the Check Sum are used.

◎ Driver's response: **%(25H)**

If there is a Check Sum error in the read command, then the driver returns “!(21H)”

For Monitor Mode Address 128(80H) ~ 157(9DH), the data sent to the driver is the number of times, which the driver will respond with the content stored in the specified address. For example: Sending a string of “W5800008BC” will cause the driver to respond with the content stored in address 80H for **eight times**. The format of the response string is the same as “R5” read command. This function can be used to monitor a certain data such as speed or torque continuously. Writing a “zero” to one of these addresses will clear the content store at that address.

©To write a **DOUBLE-WORD** to driver

Syntax : **M5NnXxYyAaBbSs** The write command must be started with “M5” and the command string length must be “14”.

Where: M5: This is a double-word write command.  
Nn = the address of the data to be written.  
Xx = the high word of the data to stored in Nn+1  
Yy = the Low word of the data to stored in Nn+1  
Aa = the high word of the data to stored in Nn  
Bb = The Low word of the data to stored in Nn  
Ss = 'M'+ '5'+ 'N'+ 'n'+ 'X'+ 'x'+ 'Y'+ 'y'+ 'A'+ 'a'+ 'B'+ 'b'

© Driver's response: **%(25H)**

If there is a Check Sum error in the read command, then the driver returns “!(21H)”

For Monitor Mode Address 128(80H) ~ 157(9DH), the data sent to the driver is the number of times, which the driver will respond with the content stored in the specified address. For example: Sending a string of “M58000080008Ss” will cause the driver to respond with the content stored in address 81H and 80H for **eight times**. The format of the response string is the same as “L5” read command. This function can be used to monitor a double-word data such as accumulated pulses continuously. Writing a “zero” to one of these addresses will clear the content store at that address.

## 2.6.4. Memory map

Address	Descriptions
0~9	Historical Alarm Codes (NO.0~NO.9)
10	Address of the last Alarm (0~9)
11	User Parameter Check Sum (NO.0~NO.51, XOR)
12~63	User Parameter (NO.0~NO.51), Read/Write, unsigned.
64~79	Reserved for USER as the motor model
80~93	Motor Parameter
94	Backup copy of Addr11
95~127	Default values for User Parameters (NO.32~NO.0)

128~147	Monitor Mode (NO.0~NO.19), Read only, signed.
148~157	Monitor Mode Data Area. See Section 2.8.3 for detailed information.
158~191	Reserved
192(C0H)	<ol style="list-style-type: none"> <li>Address 11 is the check sum of Address 12~63. Any value change in Address 12~63 will cause Address 11 to be changed accordingly.</li> <li>Writing a “0” to this address (192) will disable the updating function of the Address 11. Writing a “1” to this address (192) will enable the updating function. The system default is “enable”.</li> <li>During the “disable” state, writing any value to Address 11 will cause the Check Sum to be regenerated.</li> <li>If there is many User Parameters need to be changed, disabling the Check-Sum updating function is highly recommended to prevent excessive writing of EEPROM. After changing all the User Parameters, a write operation to Address 11 may then be executed.</li> </ol>
193(C1H)	Clear historical Alarm codes, the contents in Address 0~10are cleared.
194(C2H)	Writing a “1” to this address will initialize the driver with the setting stored in the address 12 ~63; the block, where a user is not allow to change, is excluded.
195(C3H)	Firmware version, the format is similar to that of Fn003. For the numbering of year, 0 ~ 9 stands for Year2000~2009; A ~Z stands for Year 2010 ~ 2035, respectively.
196(C4H)	RESET
197(C5H)	Input Status, the description of each bit is shown in Section 3.2.6.
198(C6H)	Output Status, the description of each bit is shown in Section 3.2.7.
199(C7H)	Current Alarm code, “0” means no alarm.

### 3. Panel operation

Name	Function
MODE	Mode selection, press this key for more than 1 second to confirm the flashing function
▲	Increase the flashing digit by 1
▼	Decease the flashing digit by 1 • press ▲ and ▼simultaneously to clear the alarm
DATA	Shift the cursor (the flashing digit) left by 1 position. Press this key for more than 1 second to select or store the data into the EEPROM (PN)

### 3.1. Mode selection :

There are 3 modes to select from: Auxiliary function, Parameter setting, and Monitoring. Press the MODE key repeatedly to cause the displays to scroll in the following sequence:

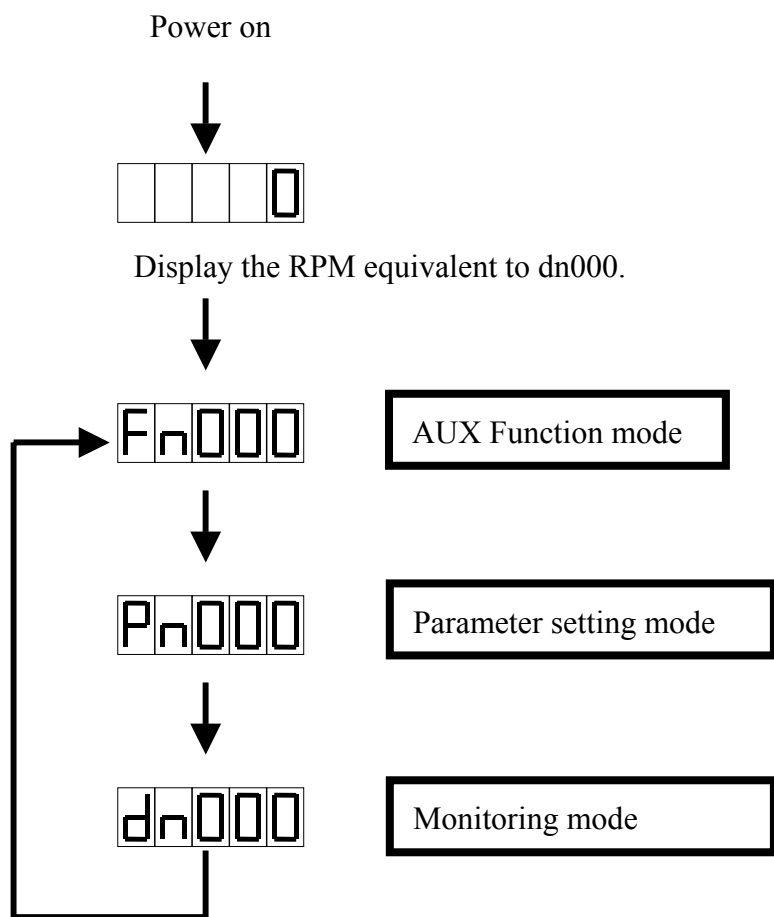

### 3.2. Auxiliary functions

Press the MODE key repeatedly until the following pattern is displayed.



### 3.2.1. Historical alarm code

The last 10 alarm codes are stored in the EEPROM.

Use the following procedures to retrieve the stored alarm codes.

1. Select the auxiliary function mode.

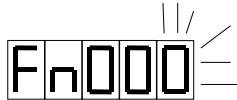

2. Press the DATA key for more than 1 second.

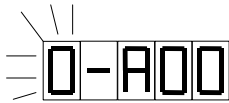

3. Press the ▲ key or the ▼ key to scroll up and down among the previous alarm codes. The leftmost number is the alarm sequence, where “9” means the oldest.
4. Press the DATA key for more than 1 second to return to the auxiliary function mode.

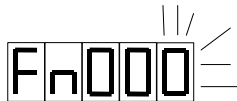

### 3.2.2. Clear the historical alarm codes

1. Press the ▲ key or the ▼ key to select function 1.



2. Press the DATA key for more than 1 second until the following message appears.

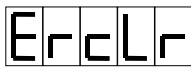

3. Press the MODE key to clear the memory.

 Flash for 1 second.  $\longrightarrow$  

4. Press the DATA key more than 1 second to return to the auxiliary function mode.

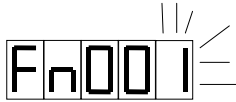

### 3.2.3. Jog

Jog uses the speed specified in the PN29 and the acceleration time specified in the PN28.

1. Press the  $\blacktriangle$  key or the  $\blacktriangledown$  key to select the jog function 'Fn002'.



2. Press the DATA key for more than 1 second.



3. Press the  $\blacktriangle$  key or the  $\blacktriangledown$  key to jog in positive or negative direction.



Jog in positive direction.



Jog in negative direction.



Hold.

4. Press the DATA key for more than 1 second to return to the auxiliary function mode and close the jog function.

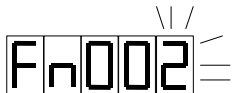

### 3.2.4. Firmware version

1. Press the  $\blacktriangle$  key or the  $\blacktriangledown$  key to select the function 3.



2. Press the DATA key for more than 1 second to display the firmware release date :

 Represents the date: 26 JAN 2006

Counting from left to right, the first and second digit represents YEAR. The third digit represents the month. 1、2、3、4、5、6、7、8、9、A、b、C represent JAN to DEC respectively. The figures are shown as following:



The fourth and fifth digit represents the Date.

4. Press the DATA key for more than 1 second to return to the auxiliary function mode.



### 3.2.5. Reset – Warm start

1. Press the ▲ key or the ▼ key to select the function 4.



2. Press the DATA key for more than 1 second, and the following pattern is displayed.



3. Press the MODE key to confirm the reset, Press the DATA key for more than 1 second to abort the reset.

### 3.2.6. Input ports status

PIN number	Definition
1	Servo on
2	Clear error counter
3	Pulse command inhibit

1. Press the ▲ key or the ▼ key to select the function 5.



2. Press the DATA key for more than 1 second, the displays will show the pin

number in left 3 characters and show the status in rightmost digit. ***If the status digit is 1, which means the pin is connected to DG or 0V or close. If the status digit is 0, which means the pin is connected to 24V or open.***

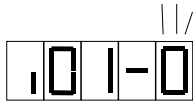

3. Press the ▲ key or the ▼ key to scroll up and down to view all the input ports.
4. Press the DATA key for more than 1 second to return to the auxiliary function mode.

### 3.2.7. Output ports status

PIN number	Definition
14	Alarm
15	In Position

1. Press the ▲ key or the ▼ key to select the function 6.



2. Press the DATA key for more than 1 second, then the display will show the pin number in the left 3 characters and show the status in rightmost digit. ***If the status digit is 1, which means the pin is connected to DG or 0V or close. If the status digit is 0, which means the pin connect to 24V or open.***



3. Press the ▲ key or the ▼ key to scroll up and down to view all output ports.
4. Press the DATA key for more than 1 second to return to the auxiliary function mode.

### 3.2.8. Reload the default values

Function: reload the default values for Pn0 ~ Pn32

**Procedure of this function: Fn010 → Fn009.**

1. Press the ▲ key or the ▼ key to select the function 9.

Fn009

2. Press the DATA key for more than 1 second to request for a parameter initialization function.

Pinit

3. Press the MODE key to confirm the request.

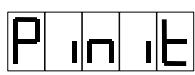
Pinit Flashes while reloading. →

done Flashes for 1 second. → Pinit

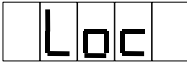
This function is locked to prevent unintentionally activation. If this function was activated before unlocking, a Loc message is displayed.

4. Press the DATA key for more than 1 second to return to the auxiliary function mode.

Fn009

### 3.2.9. Lock & Unlock

Functions 7, 8 and 9 are locked normally to prevent unintentionally activation. The following procedures can be used to unlock these functions.

1. Press the ▲ key or the ▼ key to select the function 10.

Fn010

2. Press the DATA key for more than 1 second to request the unlock function.

UnLoc

3. Press the MODE key to confirm the request

 Flashes while unlocking. →

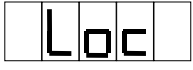
 Flash for 1 second. → 

Press the MODE key again will lock the function again.

4. Press the DATA key for more than 1 second to return to the auxiliary function mode.



After unlocking, the function 9 or the function 7 and 8 can only executed 1 once.  
***Function 7,8, and 9 will be locked after execution.***

### 3.3. User Parameters

1. Press the MODE key repeatedly until PN000 is displayed.



Press the ▲ key or the ▼ key to get the desired parameter number.

2. Press the DATA key for more than 1 second to retrieve the content of the listed parameter number.



*If there is a leading 'H', then it is a hexadecimal number.*

3. To edit the number, press the DATA key to shift the flashing digit left. Press the ▲ key or the ▼ key to increase or decrease the flashing digit.
4. Press the DATA key for more than 1 second to store the new data into the EEPPROM. The number entered will flash for 1 second while recording.

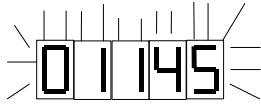

5. Press the DATA key for more than 1 second to return to the parameter setting mode.

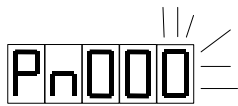

### User Parameter Table

No.	Definition	Range	Unit	Default	effect	PC r/w addre ss
0	Reserved					12
1	Speed loop gain	5~500		40	enter	13
2	Speed loop integration time	1~1000	msec	100	enter	14
3	Reserved					15
4	Reserved					16
5	Positive torque limit	0~300	%	300	reset	17
6	Negative torque limit	0~300	%	300	reset	18
7	Reserved					19
8	Reserved					20
9	Percentage of increased Speed Loop integration gain in low speed		%		reset	21
10-1	Reserved					22-1
10-2	Hxxnx, Negative logic: n=0 sign + pulse, n=1 CW + CCW, n=2/3 AB phase pulse input. Positive logic: n=4 sign + pulse, n=5 CW + CCW, n=6/7 AB phase pulse input.	0~2		1	reset	22-2
10-3	Hxnx, n=0, CCW for positive command, n=1, CW for positive command.	0,1		0	reset	22-3
10-4	Hnx, n=0, set automatic current feedback offset. n=1 set current feedback offset to 0.	0,1		0	reset	22-4
11-1	Reserved					23-1
11-2	Hxxn, n=0, normal mode. n=1, eliminate low voltage alarm	0,1		1	reset	23-2
11-3	Reserved					23-3
11-4	Reserved					23-4
12-1	Hxxn, acceleration and deceleration time for jog mode(FN2). n=0: time =0; n=1: linear acceleration. Acceleration and deceleration time is set in the parameter number 28. n=3: deceleration time is set in the parameter number 27 Acceleration time is set in the parameter number 28.	0,1,3		1	reset	24-1
12-2	Reserved					24-2
12-3	Reserved					24-3
12-4	Reserved					24-4
13-1	Hxxn, digital filter for position	0~7		0	reset	25-1

No.	Definition	Range	Unit	Default	effect	PC r/w addre ss	
	command, n=0: do not apply filter and can accept 500kpps max. n=7: apply 7 layer filters and could accept 200kpps max.						
13-2	Hxxnx,n=0: normal condition. n=1,power on and servo on automatically. Delay can be set in parameter number 32. Pn32=-2000,it means that power on and then servo on after 2 seconds.	0,1		0	reset	25-2	
13-3	Hxnx, contact definition for command pulse inhibit (CN1 pin3). NO: normally open, NC: normally close.	0		0	reset	25-3	
	n						INH
	0,1						NO
	2,3						NC
13-4	Reserved	0,1		0	reset	25-4	
14	Reserved					26	
15	Reserved					27	
16	Reserved					28	
17	Reserved					29	
18	Reserved					30	
19	Reserved					31	
20	In position, sets range of positioning completion signal output (INP).	0~32767	pulse	4	reset	32	
21	Numerator of electronic gear ratio: indicates the number of encoder pulses per reference unit. The input pulses will multiply this number to form an actual calculation number. $1/127 < (21)/(22) < 127$ .	1~10000		1	reset	33	
22	Denominator of electronic gear ratio: indicates the number of encoder pulses per reference unit. The input pulses will divide this number to form an actual calculation number. If encoder pulse=2000ppr and $(21)/(22)=1$ , motor be 8000 pulses per revolution.	1~10000		1	reset	34	
23	Position gain	10~500	1/sec	30	enter	35	
24	Position smoothing time	0~10000	msec	10	Servo on	36	
25	Error counter length	1~500	kpulse	50	reset	37	

No.	Definition	Range	Unit	Default	effect	PC r/w address
26	Feed forward gain	0~100	%	0	reset	38
27	Deceleration time: The time consumed from rated speed to stop. Parameter number 12-1 is used to disable or enable this function.	10~10000	msec	100	Servo on	39
28	Acceleration time and deceleration time: The time consumed from still to rated speed or from rated speed to still. Parameter number 12-1 is used to disable or enable this function.	10~10000	msec	100	Servo on	40
29	Jog speed	±rated speed	rpm	300	enter	41
30	Reserved					42
31	Reserved					43
32	Waiting time or delay time before servo on	2000	msec	0	reset	44
33	Reserved					45
34						46
35						47
36						48
37						49
38						50
39						51
40	Regeneration duty cycle, default value is 10. It means that if the voltage exceed 360V, there is 0.1second regeneration in every 10 second. Recommended regeneration resistor: 20A and 30A driver 50Ω,50W 40A driver 40Ω,70W If there is error 2 exists, connect an lower resistance and higher power resistor, and observe the DN8, if the value of DN8 remains divergent, then this value need to be increased. The maximum value here is resistance of the resistor (Ω) times power dissipation (W) /134 <b>Warning: avoid to burnout the driver, please watch out the temperature raise of the heat sink.</b> The minimum resistor is 25Ω.	0~250	0.1%	4	reset	52
41	Current loop smoothing time	0~10	100μs	10	reset	53
42	Torque command value for cancelling I control in velocity loop. The value=200	0~300	%	200	reset	54

No.	Definition	Range	Unit	Default	effect	PC r/w address
	means I control will be cancelled if torque command exceed 200%.					
43	Current loop Integral gain				reset	55
44	Reserved					56
45	Encoder pulse		ppr		PC	57
46	Shift: the angle of encoder index and current in U-phase			0	PC	58
47	Encoder power on delay	0~20000	μs			59
48	Encoder brand/type 0:SUMTAK 1:NEMICON 2:TAMAGAWA					60
49	A,B phase sequence on rotating CCW 0: A lead B 1: B lead A	0,1		0		61
50	Motor type				PC	62
69	Power 0: 100~120V, 100:200~220V			100	PC	81
70	Current loop proportional gain	80~200			PC	82
71	Reserved				PC	83
72	Rated speed		Rpm		PC	84
73	Maximum speed		Rpm		PC	85
74	pole		pole		PC	86
75	Reserved					87
76	Inductance		0.01 mH		PC	88
77	Rated current		0.1A		PC	89
78	Inertia		g* cm^2		PC	90
79	Voltage constant				PC	91
80	Torque constant		0.01 Nm/A		PC	92

Remarks:

1. Reset means the number is effective after reset from panel, CN1 or power off -on.
2. Enter means effective after value set.
3. PC means the value must be transfer in from the RS232 communication port.
4. Default value of Pn0~Pn32 can be reload by function 9. Pn 33~ Pn 43 can be set from panel or from communication port. Over Pn45 can only be set from the RS232 communication port.

## 3.4. Monitor mode

1. Press the MODE key repeatedly until the monitor mode is reached.



2. Press the ▲ key or the ▼ key to get the desired parameter number.
3. Press the DATA key for more than 1 second to display the content of the DN.
4. Press the DATA key again for more than 1 second to return to the monitor mode.

### The monitor mode information list:

DN number	definition	PC r/w address
0	Revolutions (rpm), e.g. 120 means current motor revolution is 120 rpm, this value is the average rpm in 0.1 second.	128
1	Torque: the value is the percentage of the rated torque of the motor. E.g. value 120 means that the current torque output is 120% of the rated torque of the motor.	129
2	Actual load: the value is the average torque output percentage in 26 seconds.	130
3	Maximum load: the value is the maximum value appeared in DN2	131
4	Error: the difference between command pulses and encoder feedback pulses. The command pulses are input pulse number multiply electronic gear ratio. The display value is clamped between -9999 ~ 9999.	132
5	Reserved	133
6	Reserved	134
7	Reserved	135
8	Regeneration rate, 100 represents 1 %.	136
9	Maximum regeneration rate, 100 represents 1 %.	137
10	Maximum torque, the maximum torque output since power on.	138
11	Driver capacity: 150 means 15A, 200 means 20A, 300 means 30A.	139
12	Speed command, 4 means 1 rpm, 12000 means 3000 rpm.	140

DN number	definition	PC r/w address
13	Reserved	141
14	Reserved	142
15	Motor type, please refer to table at the end of this section.	143
16	Servo status. 0 means 'servo on', 1 means 'servo off'.	144
17	Reserved	145
18	Reserved	146
19	Overload counter, the counter is incremented if a transient overload is detected; when this counter reaches 1250, "Overload" warning is issued.	147
20	Lower word of accumulated pulses count, 32 bits in total, higher word is not displayed.	
21	Lower word of feedback pulses count, 32 bits in total, higher word is not displayed.	
30	Error: the difference between command pulses and encoder feedback pulses. The command pulses are input pulse number multiply electronic gear ratio.	148, 149
31	Accumulated input pulses.	150, 151
32	Accumulated encoder feedback pulses.	152, 153
X	RPM: 4 means 1RPM. E.g. 480 means current motor speed is 120 rpm, this is a sampled value in 1 of 50 samples taken in 10 milliseconds.	154
X	Torque: output percentage of the rated torque. 120 means the torque output now is 120% of the rated torque. This is a sampled value in 1 of 50 samples taken in 10 milliseconds.	155

DN number X : these values can only be read/written via the RS232 communication port.

## 4. Alarm code

A message such as **E1-01** indicating that an error has occurred. The message will stay until any key is pressed.

Error code	To remove	Definition
1	reset	Low voltage (DC voltage below 250V, or AC voltage below 180V, see note 1, 2).
2	reset	Over voltage (DC voltage over 390V, note 1,2), most of the case is happened on a large inertia. Please watch DN9 while running. If this value becomes bigger and never return to 0, please add an external resistor for regeneration. Please refer to PN40. The alarm also happens on high AC line voltage.
3	reset	Over load, a 200% rated load can last for about 10 seconds, a 300% load can last for about 4 seconds.
4	Power off	IPM error, due to high temperature, short-circuit, over current or low control voltage in IPM, the device which provides power to the motor.
5	reset	Encoder error, the signal from encoder is erroneous, please check connection or encoder.
6	reset	CPU error, watch dog time out. The CPU already lost control. To prevent H/W damage, CPU reset is automatically issued.
7	reset	Parameter error—the electronic gear rate is not in the range (0.02~50).
8	reset	Parameter checksum error. The data stored in EEPROM may be corrupted.
9	reset	Emergency stop.
10	reset	1. Over current (300% rated current), please check the motor connection. Or, 2. Specify a longer acceleration/deceleration time.
11	reset	Error-counter overflow: (the difference of command pulses and feedback pulses is larger than the range of error-counter, which is defined in PN25).
12	reset	Over speed, the speed exceeds the value defined in the PN46.
13	reset	Peak input pulse exceeds 600kpps.
14	Reserved	
15	Reserved	
16	reset	An abnormal value was read from the current sensors during power on.

Error code	To remove	Definition
18	reset	Voltage be too high as power on. 1.DC voltage over 360V, or AC voltage over 255V. 2.The voltage monitor device does not work

Note 1: Due to the accuracy of the resistor, the voltage detected has a maximum error of 2.02%.

Note 2: If the rated voltage of the motor is 100 V, the voltage level to alarm will be half of the value listed (DC112V for low voltage, DC250V for over voltage).

Note 3: There are 3 methods to reset the driver. Power cycle (Power off then on), Fn004, and send an input signal from pin2 of CN1. However, the cause of alarm must be resolved first.